



RPSTL48

RemotePro[®]

Remote Power System

- Wireless Base Stations and Client Devices
- Surveillance Cameras
- Remote Sensors
- Remote Lighting
- Off Grid Electronics



Congratulations! on your purchase of the RemotePro[®] off-grid remote power system. Please take a moment to review this Qwik Install Guide before assembly or battery installation.



**DANGER! Voltages in this system can exceed 65VDC and are very dangerous!
You Can Be Killed!**

When following the instructions in this guide take extreme care to avoid contact with output of solar panels. Only licensed electricians or those with experience working around high voltage should attempt to install.

Safety: For your own protection, follow these safety rules.

- **Perform as many functions as possible on the ground**
- **Do not attempt to install on a rainy, windy or snowy day or if there is ice or snow accumulation at the install site or if the site is wet.**
- **Make sure there are no people, pets, etc. below when you are working on a roof or ladder.**



Recommended Tools: Phillips & Flat Screwdriver, 17/13/10mm wrench, 8mm nut driver



Please help preserve the environment and return used batteries to an authorized depot. Most auto parts stores will pay for your used battery.

Qwik Install

STEP 0: Install mounting pole per separate instructions.

STEP 1: Prepare the enclosure: Install DIN rail (if required) to door using two phillips head screws. Install just the top mounting bracket to the enclosure using two 8mm bolts.

NOTE: It takes two people to mount the enclosure to a pole. The standard U-Bolt mounting accommodates a pole up to 4" diameter. Multiple pole straps can be used for extra strength. Pole straps are available for poles up to 11" diameter or larger.

NOTE: It's a good practice to mount the enclosure under the shade of the solar panel array to help keep the electronics and batteries as cool as possible. This will extend the useable life of the batteries.

STEP 2: Install the bottom bracket and stabilizer bracket to the pole using U-Bolt and Pole Straps. The stabilizer bracket is used as an aid to mounting and additional support when mounted.

STEP 3: Lift the enclosure and place it on the stabilizer bracket. Connect the top bracket to the pole using U-Bolt and Pole Straps.

STEP 4: Attach The two 8mm bolts that hold the bottom bracket to the enclosure. Make sure all bolts are tight. (8-15 ft lbs)

STEP 5: Install the three wire feedthru cable glands in the holes in the bottom of the enclosure. If one or more of the cable glands will not be used, just cut a short piece of cable and tighten in the cable gland to seal it.

NOTE: The bottom plate can be removed from the enclosure if you need to add some additional feedthru. (ex; conduit connection)

STEP 6: Install the batteries in the enclosure. For 48VDC the batteries are connected in series pairs. (See wiring diagram).

NOTE: The enclosure has slot features that can be used to strap the

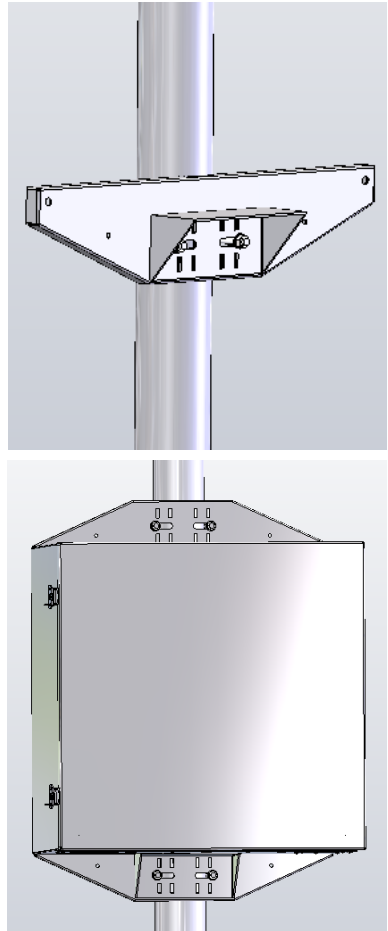

batteries if desired. Tycon has velcro straps available. It takes two straps per battery.

STEP 7: Before attaching the battery cables to the batteries, first remove the battery cable fuse. This will prevent accidental short circuit.

Connect all battery minus (-) connections, then connect all battery plus (+) connections.

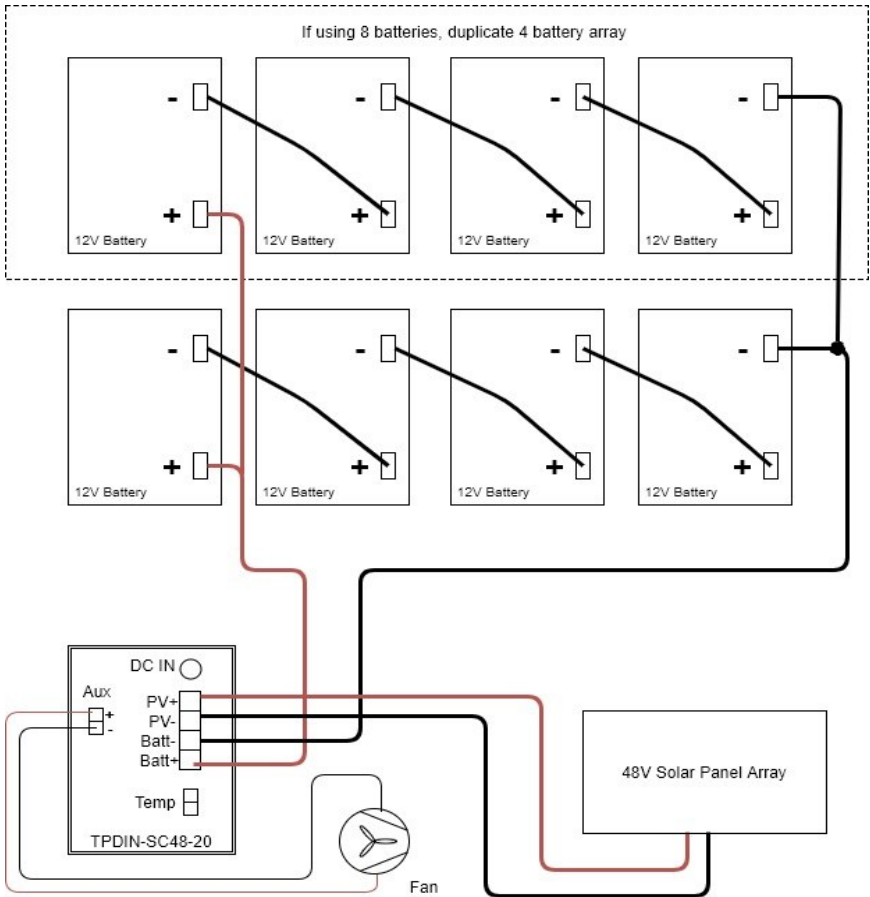

RPSTL48 Wiring Diagram

WARNING! The fan supplied with the system operates on 12VDC or 24VDC. It is thermostatically controlled to turn on if temperature exceeds 45C. It cannot be connected to 48V battery voltage. It can be connected to the Aux output of the controller set to 24VDC or it can be connected across one of the batteries in the array.

STEP 8: Install the Solar Controller to one of the DIN rail mounts on the inside of the enclosure. To attach, place the bottom of the DIN rail bracket over the bottom of the DIN rail and then push the controller up and over the top of the DIN rail. To remove, reverse the process.

STEP 9: Attach the solar panels to the solar panel mount so that the wire junction box is towards the inside. For the 320W array, remove the cover from the solar panel junction box by releasing the snaps with a small flat blade screwdriver. Connect the wires to the + and - screws inside the junction box. Clean the gasket and replace the cover making sure it is fully snapped in place. For the 500W and 1000W arrays the solar panels are equipped with integrated cables with solar connectors.

STEP 10: Wire the solar panels in a 48V configuration. They will be wired in series for the 320W and series pairs for the 500W and 1000W. (See wiring diagram on next page)

NOTE: In the 320W configuration there will be two unused wires from the cable assembly. Just tape the ends to avoid any shorting.

STEP 11: Connect the battery wires to the solar controller BATT inputs. Be sure to pay strict attention to polarity. **CAUTION: Wiring with a reverse polarity can cause equipment damage. Wiring solar panels to BATT input can cause equipment damage.**

Replace the fuse in the battery cable(s) to power up the controller. When the controller is first powered up, the CHARGING LED will light for about 60 seconds.



WARNING: Always connect the battery to the controller first and disconnect the battery last. You can disconnect the battery by removing the cable in-line fuse.

STEP 12: Route the long solar panel cable(s) through one of the feed-thru in the bottom of the enclosure. This cable can be cut to length. The shorter the cable, the lower the cable losses. Connect the cable - wire to the Solar Controller PV - input. Connect the cable + wire to the solar controller PV + input. Be sure to pay strict attention to polarity. **CAUTION: Wiring with a reverse polarity can cause equipment damage.**

NOTE: You can lengthen the solar cable if necessary. Use 12AWG or larger cable. Increasing cable length will increase cable loss.

STEP 13: Connect the Solar Panel cable from the solar controller to the connectors from the solar panel. Connect - first and + second.

STEP 14: Tighten all wire feedthrus. If they don't tighten on a small diameter wire, you can wrap some electrical tape around the wire in the seal area to increase its diameter and make a better seal.

STEP 15: Make sure the enclosure door gasket is clean, then close the door making sure all wires are clear. The enclosure can be locked using a standard combination or keyed padlock.

TECH CORNER

Additional Information you may find useful

1. **CONTROLLER:** The MPPT controller with 7 port PoE gigabit switch is designed for use with 48V battery and 48V solar panels. It has a settable low voltage disconnect function to shut down the load power when the battery voltage drops below a pre-defined level. Maximum solar current is 20A. You will need to access the web interface of the controller to setup the various built-in functions. Refer to the controller user guide which came with the controller.

2. **Fuse:** There is a fuse in-line in the battery cables. If fuse is blown there was some sort of short in the battery connection and the controller will appear dead. Replace with 3AG 6.3 x 32mm 20A Slo-Blo fuse..

3. **VENTING:** The enclosure is vented thru a thermostatically (45C) controlled fan and top and bottom vents. The vents are covered with dust/insect filters. You should add the checking/cleaning of the filters during any routine maintenance cycle but at least annually.

4. **BATTERY MAINTENANCE:** The batteries used in the RemotePro® systems don't require any maintenance. They should last up to 5 years in normal use. **Note: Never store batteries for any length of time in a discharged state or it may kill the battery. Always fully charge before storage.**

5. **SOLAR PANEL TILT:** There is a solar panel tilt calculator at the TyconSystems website <http://tyconsystems.com>. We recommend using a fixed tilt and setting to optimize for winter sun. The panel should face South if you are in the Northern Hemisphere and face North if you are in the Southern Hemisphere. Some typical winter tilt angles are as follows:

<i>Place</i>	<i>Optimum Winter Tilt</i>
Houston / Cairo	56 deg
Albuquerque / Tokyo	60.5 deg
Denver / Madrid	65 deg
Minneapolis / Milano	69.5 deg
Winnipeg / Prague	74 deg

6. **BATTERY OVERDISCHARGE:** We highly recommend hooking all equipment loads to the controller load outputs. This output will disconnect the loads if the battery voltage drops below the level that is setup in the user interface, normally around 47V and this will protect the battery from over-discharge. If batteries get completely discharged because the equipment was connected directly to the battery, you will reduce the battery life and you will most likely need to supercharge them

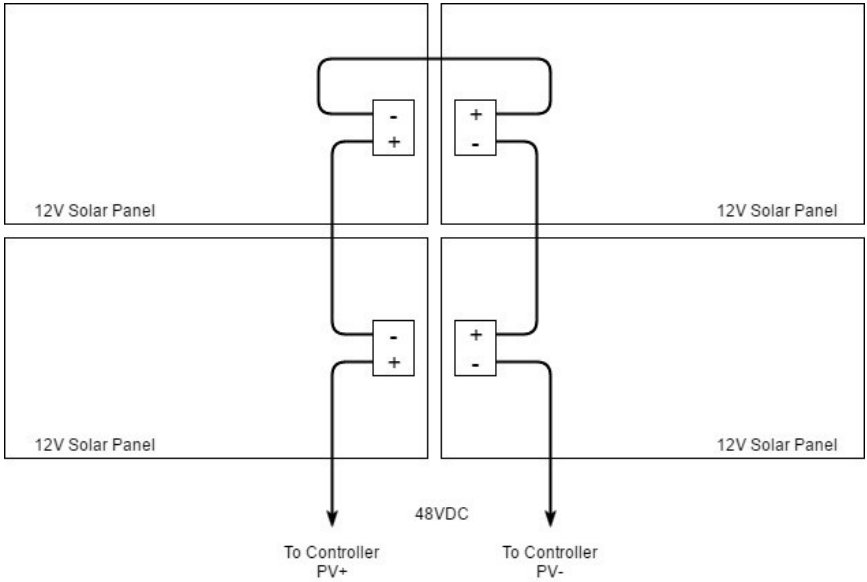

48V 320W Configuration using 12V Solar Panels

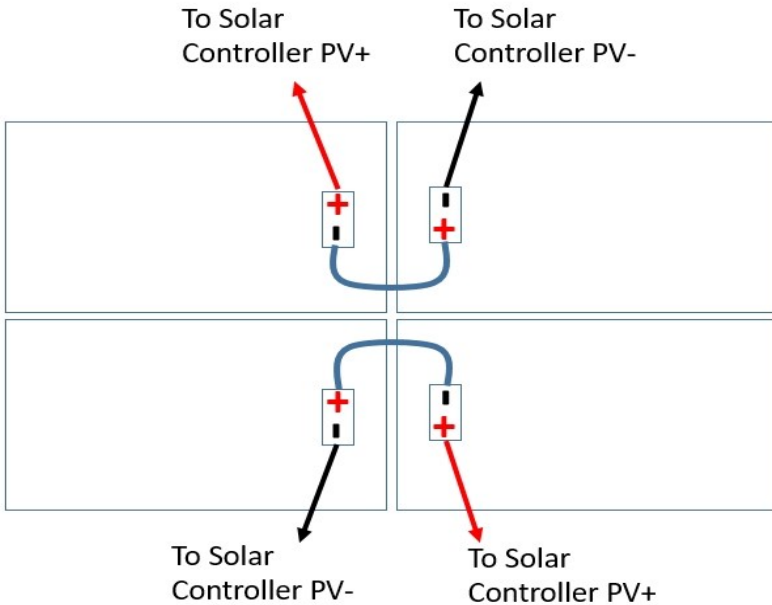

48V 650W and 1300W Config using 24V Solar Panels.

Note: For 650W use 1/2 of above configuration

with a good quality 10A automotive battery charger. Once they are back to a normal operating range, the integrated charge controller will maintain the charge. Don't charge batteries using an automotive charger for longer than 8hrs or you may damage the battery.

7. TROUBLESHOOTING:

- A. ***The lights on the solar controller look fine but the batteries aren't charging?*** The battery voltage and solar panel voltage must match. Check to make sure Solar Panels are wired in series for 48V.
- B. ***There is no voltage output?*** If battery voltage is too low the charge controller will turn off the load outputs. This typically happens when battery voltage falls below around 47V.
- C. ***Why is my solar panel voltage so high?*** Open circuit voltage on a 48V panel could be as high as 80V. Once you connect to the charge controller the panel voltage will be reduced to a little higher than the battery voltage.
- D. ***My system turns off at night and comes back on in the morning?*** This is a sure sign that the solar panels and/or battery capacity can't support the load. You should measure your actual load and recalculate to make sure you have adequate solar and battery capacity. Make sure there is no shading of solar panels during the day.
- E. ***There is no power at the solar controller?*** Check the battery cable fuse. Check the controller fuse. Measure battery voltage at the solar controller it should be >9V. If less than 9V then batteries will need to be charged with an external charger to bring the voltage up to normal operating range of the controller.

NOTES

Replacement Parts

Solar Controller: TPDIN-SC48-20

Batteries: TPBAT12-52

320W Solar Mount: TPSM-80X4-UNI

650-1300W Solar Mount: TPSM-250x4-TP

320W Solar Panel Config: TPS-12-80W

650-1300 Solar Panel Config: TPS-24-325W

Limited Warranty

The RemotePro® products are supplied with a limited 36 month warranty which covers material and workmanship defects. This warranty does not cover the following:

- Parts requiring replacement due to improper installation, misuse, poor site conditions, faulty power, etc.
- Lightning or weather damage.
- Physical damage to the external & internal parts.
- Products that have been opened, altered, or defaced.
- Water damage for units that were not mounted according to user manual.
- Usage other than in accordance with instructions and the normal intended use.

Tycon Systems
14641 S 800 W
Bluffdale, UT 84065
support@tyconsystems.com
PH: 801-432-0003

SPECIFICATIONS

Subject to change without notice

	RPSTL48-100-320	RPSTL48-100-650	RPSTL48-100-1300
Battery Capacity	400Ah	400Ah	400Ah
Rated Load @ peak sun hrs	80W @ 6hrs sun	100W @ 3.7hrs sun	100W @ 1.9hrs sun
Reserve Power @ Rated Load	>30hours	>24 hours	>24 hours
Load Voltage (DC)	24V or 48V 200W Maximum Total Load		
Battery Voltage (DC)	48V		
Battery Type	Valve Regulated Sealed Lead Acid / AGM		
Battery Life	5 Years		
Controller Type	48V 20A MPPT Battery Charge Controller with 7 port Gigabit PoE switch and remote management		
Over-discharge protection	45.8V to 47.8 – settable in web interface		
Over-discharge recovery volts	48.1V to 49.2V – settable in web interface		
Controller Self Consumption	3.5W Typical		
Enclosure Type	Powder Coat Steel		
Operating Temperature	-30°C to +60°C		

